

Rimage 2000i™ User Guide



R I M A G E®



Corporate Headquarters:

Rimage Corporation
7725 Washington Avenue South
Minneapolis, MN 55439
USA

800-553-8312 (toll free US)

Service: +1 952-946-0004 (Asia/Pacific, Mexico/Latin America)

Fax: +1 952-944-6956

European Headquarters:

Rimage Europe GmbH
Albert-Einstein-Str. 26
63128 Dietzenbach
Germany

Tel: +49-(0) 6074-8521-0

Fax: +49-(0) 6074-8521-100

Rimage Corporation reserves the right to make improvements to the equipment and software described in this document at any time without any prior notice. Rimage Corporation reserves the right to revise this publication and to make changes from time to time in the content hereof without obligation of Rimage Corporation to notify any person or organization of such revisions or changes.

This document may contain links to web sites that were current at the time of publication, but may have moved or become inactive since. This document may contain links to sites on the Internet that are owned and operated by third parties. Rimage Corporation is not responsible for the content of any such third-party site.

©2008, Rimage Corporation

Rimage® is a registered trademark of the Rimage Corporation. Rimage 2000i™ is a trademark of the Rimage Corporation. Dell™ is a trademark of Dell Computer Corporation. FireWire™ is a trademark of Apple Computer, Inc. Windows® is a registered trademark of Microsoft Corporation.

All other trademarks and registered trademarks are the property of their respective owners.



Contents

Introduction	1
About this User Guide.....	1
About Your Product.....	1
Important Information	3
Support Information	3
Learn More Online	3
Technical Support	3
Optical Disc Recording Software Disclaimer	4
Safety and Compliance Information.....	4
Safety Precautions	4
Compliance Information	5
Rimage 2000i Specifications.....	6
Printer Requirements	9
Ink Requirements.....	9
Label Design Requirements.....	10
Print Requirements	10
Identify the Parts of the Rimage 2000i	11
Front View.....	11
Back View	11
Parts Information.....	12
Operator Panel.....	12
Printer Control Panel.....	12
Operate the Rimage 2000i	13
Power On the Rimage 2000i.....	13
Pause the Rimage 2000i.....	13
Load Discs	13
Set Your Printing Preferences on a Windows-based PC	14
Access Printing Preferences	15
Access Printing Preferences through Windows Start Menu.....	15
Access Printing Preferences through CD Designer	15
Set the Print Quality	15
Create, Edit, or Delete a Watermark	16
Adjust the Ink Volume Used	16
Set Color Options	17
Set the Printable Area	17
Align the Ink Cartridges	18
Center the Image on the Disc.....	19
Check the Ink Levels.....	19
Maintain the Rimage 2000i	21
Preventative Maintenance Schedule	21
Remove Dust from the Rimage 2000i.....	22
Clean the Ink Cartridges	24
Replace Consumables.....	24
Replace the Fan Filter	24
Replace the Ink Cartridges.....	25
Diagnostic Tests.....	26
Access Diagnostic Test Mode.....	26
Select a Diagnostic Test.....	26
Diagnostic Test 3 – Calibrate Diagnostic Test	26
Align the Printer on the Rimage 2000i	27





3

Introduction

This manual provides the information needed to operate, identify the parts of, and configure the printing preferences for the Rimage 2000i. To set up and install your Rimage 2000i, refer to the *Rimage 2000i Setup and Installation Guide* included with your product.

 **Note:** There are two setup and installation guides for the Rimage 2000i, one for Rimage 2000i Software, and one for OfficeNET Software Suite. Make sure you use the correct setup and installation guide for your Rimage 2000i.

About this User Guide

- While we try to maintain all versions of our manuals and documentations, please note that the English version found on our website always contains the most up-to-date information.
- Unless otherwise indicated, all Windows navigation statements are Windows XP paths. Windows Vista, Windows 2000, and Windows Server 2003 navigation may differ slightly.
- These symbols are used throughout the manual to help clarify information:
 -  **Note:** A Note provides supplemental information or information that may apply only in special cases. For example, memory limitations, equipment configurations, or details that apply to specific versions of a program would be included in a Note.
 -  **Tip:** A Tip provides techniques and procedures to help with your specific needs. A Tip suggests alternative methods that may not be obvious and helps you understand the benefits and capabilities of the product.
 -  **Important!** An Important note provides information essential to the completion of a task. You can disregard information in a note or tip and still complete a task, but do not disregard an Important note.
 -  **Caution:** A Caution indicates that failure to observe this guideline could result in loss or damage to the equipment, product, software, or data.
 -  **Warning!** A Warning indicates that failure to follow this guideline could result in bodily injury to personnel operating or maintaining the equipment.

About Your Product

The Rimage 2000i is part of the Desktop series of autoloaders. It is a robotic-controlled autoloader with two recorders, a two-line display panel, and an embedded 480i printer. The Rimage 2000i records and prints discs. When the discs are finished, the Rimage 2000i places them in the output bin.

Notes:

- The terms “480i printer” and “Rimage 2000i printer” are used throughout this guide to refer to the embedded 480i printer.
- Your Rimage 2000i may not look exactly like the model featured in this user guide.

The Rimage 2000i operates with either Rimage 2000i Software or OfficeNET Software Suite. When installed with OfficeNET Software Suite, the Rimage 2000i can be shared on a network, allowing all users to create discs from their desktops. For more information about setting up and submitting orders over a network, refer to the *Rimage Advance Setup (Networking) Guide* available at www.rimage.com/support. From the **Support** menu select: **Desktop Series > Rimage 2000i > User Manuals** tab.

Important Information

This section provides support contact information, safety and compliance information, and product specifications for the Rimage 2000i.

Support Information

US, Asia/Pacific, Mexico/Latin America	Europe
<p>Rimage Corporation 7725 Washington Avenue South Minneapolis, MN 55439 USA Attn: Rimage Services</p>	<p>Rimage Europe GmbH Albert-Einstein-Str. 26 63128 Dietzenbach Germany</p>
<p>Contact Rimage Support Website: www.rimage.com/support KnowledgeBase: http://rimage.custhelp.com Login and select the Ask a Question tab. Phone: North America: 800-553-8312 Asia/Pacific, Mexico/Latin America: 952-946-0004 Fax: 952-946-6956</p>	<p>Contact Rimage Services Europe: Website: www.rimage.de Email: support@rimage.de Phone: +49-(0) 1805-7462-43 Fax: +49-(0) 6074-8521-100</p>
<p>When you contact Rimage Services, please provide:</p> <ul style="list-style-type: none"> • System serial number and software version • Functional and technical description of the problem • Exact error message received 	<p>My Rimage Product Information: Copy this information from your Rimage product for future reference.  Note: Update the Serial Number here any time you receive a replacement autoloader.</p>
	<p>Serial Number:</p>
	<p>Product Name:</p>
	<p>Date of Purchase:</p>

Learn More Online

At www.rimage.com/support, you can experience Rimage's world-class Support and Services.

<p>From the Support home page:</p> <ol style="list-style-type: none"> 1. Select your product series. 2. Select your product. 3. Learn more on the product page. 	<p>From your product page you can access:</p> <ul style="list-style-type: none"> • Information about the latest software and firmware updates • Product specifications • The latest documents • Current firmware and driver downloads
--	---

Technical Support

Support for the Rimage 2000i is available through your authorized reseller.

 **Important!** Make sure to register your Rimage 2000i so Rimage can notify you of upgrades as they become available.

Optical Disc Recording Software Disclaimer

This Product, Software, or Documentation may be designed to assist you in reproducing material in which you own the copyright or have obtained permission to copy from the copyright owner. Unless you own the copyright or have permission to copy from the copyright owner, you may be violating copyright law and be subject to payment of damages and other remedies. If you are uncertain about your rights, you should contact your legal advisor. If you are neither in possession of the copyright nor have authorization from the owner of the copyright, unauthorized copying of copyrighted material on an optical disc or any other media violates national and international legislation and can result in severe penalties.

Safety and Compliance Information

This manual and the indications on the product allow proper and safe operation. The indication marks below help protect you and other persons from injury, and equipment from damage.

 **Warning!** According to ANSI (American National Standards Institute) standards, a warning is used to indicate situations that could result in bodily injury to personnel operating or maintaining the equipment.

 **Caution:** Indicates that failure to observe this guideline could result in loss or damage to the equipment, product, software, or data.

Safety Precautions

To ensure safety, read these precautions and familiarize yourself with their meaning before using the equipment.

Warning!

- An authorized technician should perform all service procedures.
- Use of controls or adjustments or performance of procedures other than those specified herein may result in hazardous radiant exposure.
- The laser beam used by the DVD-R recorder is a Class 1 laser and can be harmful to the eyes. Do not attempt to open the recorder. An authorized technician should perform all service procedures.
- Ink may be harmful if swallowed. Avoid contact with eyes. Ink contains nitrites. If ingested, seek immediate medical attention. Keep out of reach of children.

Caution:

- All equipment with AC line voltage, or low DC voltages, such as switches, power supplies, fuses, fans, non-stepper motors, must be replaced with Rimage-approved components to maintain the safety approval issued by UL.
- Use only the supplied AC power cord. For more information or to order a new power cord, contact Rimage Customer Service.
- This product is designed for an office environment.
- Rimage ink cartridges are not licensed for modification.
- Refilling ink cartridges may result in damage to the cartridge or printer.

Compliance Information

Product name	Rimage 2000i
Model	RAS16
Notice for USA	<p>Tested to Comply with FCC Standards FOR HOME OR OFFICE USE.</p> <p>This device complies with part 15 of the FCC Rules. Operation is subject to the following two conditions: (1) This device may not cause harmful interference, and (2) this device must accept any interference received, including interference that may cause undesired operation. Pursuant to Part 15.21 of the FCC Rules, any changes or modification to this equipment not expressly approved by Rimage Corporation may cause harmful interference, and void your authority to operate this equipment.</p> <p>NOTE: This equipment has been tested and found to comply with the limits for a Class B digital device, pursuant to Part 15 of the FCC Rules. These limits are designed to provide reasonable protection against harmful interference in a residential installation. This equipment generates, uses and can radiate radio frequency energy and, if not installed and used in accordance with the instructions, may cause harmful interference to radio communications. However, there is no guarantee that interference will not occur in a particular installation. If this equipment does cause harmful interference to radio or television reception, which can be determined by turning the equipment off and on, the user is encouraged to try to correct the interference by one or more of the following measures:</p> <p>Reorient or relocate the receiving antenna. Increase the separation between the equipment and receiver. Connect the equipment into an outlet on a circuit different from that to which the receiver is connected. Consult the dealer or an experienced radio/TV technician for help.</p>
Notice for Canada	<p>This Class B digital apparatus complies with Canadian ICES-003. Cet appareil numérique de la classe B est conforme a la norme NMB-003 du Canada.</p> <p>This product complies with CAN/CSA-C22.2 No. 60950-00 3rd Edition.</p>
Notice for Europe	<p>This product is in conformity with the EMC Directive (89/336/EEC) and the Low-Voltage Directive (73/23/EEC) through compliance with the following European standards: EN 55022: 1998 + Amd 1: 2000 Class B Limit; EN 55024: 1998; EN 61000-3-2:2000; EN 61000-3-3:1995 + Amd 1: 2001; EN 60950: 2000. The CE mark has been affixed in accordance with the CE Marking Directive 93/68/EEC.</p>
Notice for Japan	<p>This is a Class A product based on the standard of the Voluntary Control Council for Interference by Information Technology Equipment (VCCI). If this equipment is used in a domestic environment, radio interference may occur, in which case, the user may be required to take corrective action.</p> <p>Translation: この装置は、情報処理装置等電波障害自主規制協議会（V C C I）の基準に基づくクラス A 情報技術装置です。この装置を家庭環境で使用すると電波妨害を引き起こすことがあります。この場合には使用者が適切な対策を講ずるよう要求されることがあります。</p>
Notice for Korea	<p>It is certified that foregoing equipment has been certificated under the Framework Act on Telecommunications and Radio Waves Act.</p> <p>위 기기는 전기통신기본법, 전파법 에 따라 인증되었음을 증명 합니다.</p>
Notice for Australia	This product complies with AS/NZS CISPR22:2006.

Rimage 2000i Specifications

 **Note:** The most up-to-date technical specification information for the Rimage 2000i is available at www.rimage.com/support. From the **Support** menu select: **Desktop Series > Rimage 2000i > User Manuals** tab.

		Rimage 2000i
Standard system		Rimage 2000i autoloader (includes the embedded Rimage 480i printer), Rimage 2000i Software Suite.
Number of recorders		2
Bin capacity	Supply bin	100 discs
	Output bin	100 discs
Physical size	Height	21.0 in (53.3 cm)
	Width	15.75 in (40.0 cm)
	Depth*	20.0 in (50.8 cm)
	Weight	62.0 lb (28.12 kg)
		*Leave an additional 3.5 in (9 cm) for cabling.
Software requirements		The Rimage 2000i ships with Rimage 2000i Software™. The Rimage 2000i operates with either Rimage 2000i Software or Rimage OfficeNET™ Software Suite. To purchase OfficeNET, contact your Rimage reseller.
Media requirements		Use only 120 mm optical discs that are coated with an ink-jet printable surface. The media in Rimage Media Kits™ are designed for optimum print performance.
Minimum PC requirements	Supported operating systems	<p> Important! If you do not understand these PC requirements, ask your computer technician for help or refer to your PC documentation.</p> <ul style="list-style-type: none"> • Windows Vista Business SP1 (OfficeNET Software Suite and Rimage 2000i Software versions 8.2 and higher only)* • Windows XP Professional SP2 (Rimage 2000i Software versions 8.1 and lower only) • Windows XP Professional SP3 • Windows 2000 Professional SP4 (Rimage 2000i Software versions 8.1 and lower only) • Windows Server 2003
	Processor	Celeron 2.0 GHz
	RAM/Memory	512 MB
	Fixed storage	2 36 GB, 7200 RPM hard drives**
	Graphics	1024 x 768 screen resolution, 16-bit color
	Ports	One USB 2.0 port
		*Rimage 2000i autoloaders using a FireWire connection are not supported by the Windows Vista operating system. **For increased performance or DVD/dual-layer disc production, an additional hard drive is recommended.

Specifications are continued on page 7.

		Rimage 2000i
Networking ability		Refer to the <i>Rimage Advanced Setup (Networking) Guide</i> for instructions on submitting orders from a networked computer.
Print quality		
	Technology	Thermal inkjet printing
	Resolution	Up to 4800 dpi
	Droplet size	3 pico-liters
	Pixel density	5.76 million pixels per square inch
Power		100 – 240 VAC, 2.7 A, 60/50 Hz
Temperature and humidity		
	Operating temperature	60° to 95° F (16° to 35°C)
	Humidity	40% to 80% non-condensing
	Storage temperature	5° to 95° F (-15° to 35°C)

Printer Requirements

This section describes the ink, label design, and print requirements for the Rimage 2000i.

Ink Requirements

ⓘ Important!

- Use only authentic Rimage ink cartridges in the Rimage 2000i.
- Keep print cartridges sealed in their original packaging until they are needed.
- Do not use ink cartridges that have expired.
- Store print cartridges at room temperature (60° to 78° F or 15.6° to 26.6° C).
- Store print cartridges in an upright position, not on their sides or upside down.
- Do not remove the protective tape from a new print cartridges until immediately before installation. After you remove the tape, do not reapply it.
- After you have removed the protective tape, do not touch the contacts and nozzles.
- Print discs at least once a month to keep the print cartridges in good working order.

The Rimage 2000i will work only with the following printer cartridges:

Description	Rimage Part Number	
Black	RB1	203340-001
Color	RC1	203339-001

The following cartridge combinations are supported on the Rimage 2000i printer:

Left Position	Right Position
Color	Black
Color	No cartridge
No cartridge	Black

Label Design Requirements

The Rimage 2000i Software includes a label editor called CD Designer™, which is installed on your PC during a typical installation of the Rimage 2000i Software. You can use CD Designer to design your labels.

If you prefer to design labels in a software application other than CD Designer, use the following criteria:

- **File format:** For best results, save your labels as JPEG or TIFF files. However, these file formats must be converted before printing. If you use CD Designer to print labels, you must import the labels and save them as CD Designer files (.btw) before printing. If you do not use CD Designer to print labels, you must convert the labels to PDF files before printing.
 - **Color mode:** Labels imported into CD Designer must be in RGB color mode.
 - **Resolution (pixels per inch):** For best results, use images set to a minimum of 300 pixels per inch.
 - **Label design size:** Design labels with a height of 12 cm and a width of 12 cm. A full-size disc is 120 mm (4.723") in diameter. The hole is 15 mm (0.59"). The printable area and hub sizes may vary between disc manufacturers.
-  **Note:** The media in Rimage Media Kits have a printable area of 118 to 24 mm. On most labels, print settings of 118 mm and 24 mm are recommended. Refer to the image below.

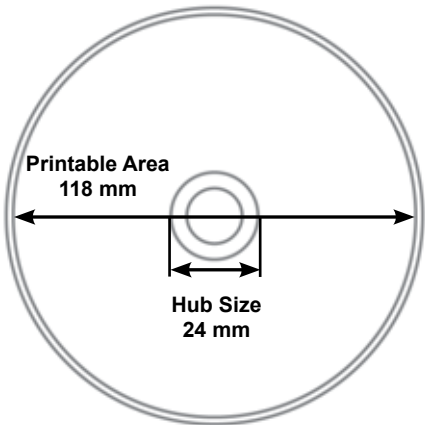

Print Requirements

All labels created and saved through CD Designer are in the correct file format (.btw) for printing with the Rimage 2000i. If you are creating and saving labels with a software application other than CD Designer, save your labels as PDF files before printing with the Rimage 2000i.

Identify the Parts of the Rimage 2000i

This section describes the Rimage 2000i hardware and its features.

Front View

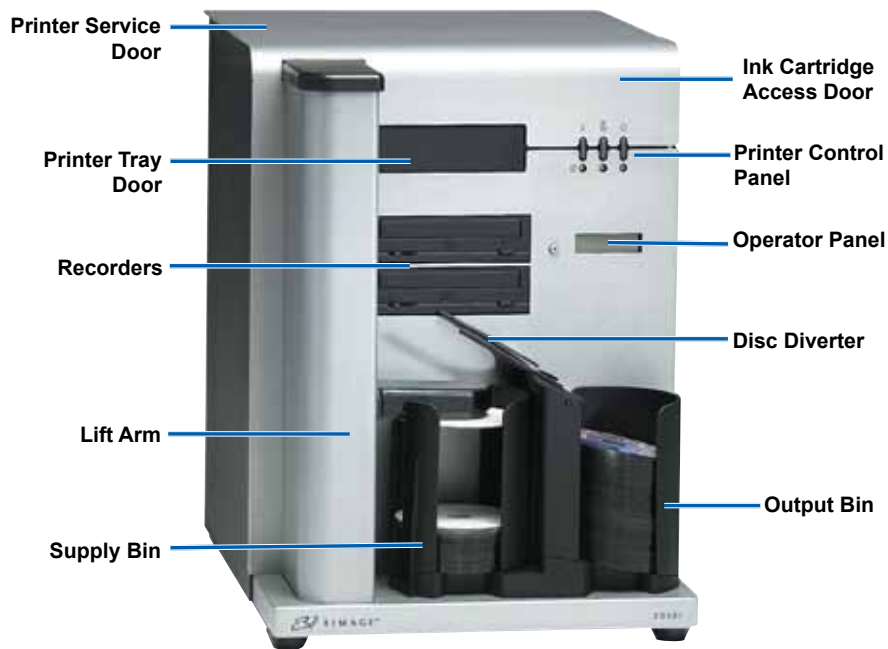

Back View



Parts Information

Operator Panel



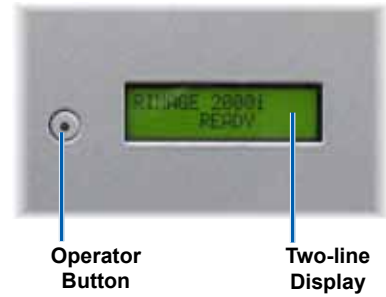

The operator panel has a two-line display and an operator button. The operator panel informs the user of current operations or conditions that require operator intervention.

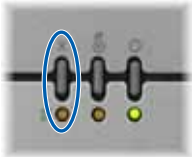

Printer Control Panel

The Rimage 2000i printer control panel has three buttons and three indicator lights that indicate certain conditions. The table below explains the functionality of each button and indicator light.



Image	Name	Functionality
	Cancel button	Press the cancel button to provide limited functionality and cancel printing.
	Ink cartridge status indicator light	The ink cartridge status indicator light flashes amber when there is a hardware issue. The ink cartridge status indicator light illuminates solid amber when an ink cartridge is low on ink.
	Tray button	Press the tray button to open and close the printer tray and to load a disc for manual printing.
	Tray indicator light	The tray indicator light illuminates briefly when the printer tray opens and closes. The tray indicator light flashes when there is a tray movement error.
	Power button	Press the power button to power the printer on or off.
	Power indicator light	The power indicator light illuminates solid green when there is power to the printer. The power indicator light flashes when the printer is printing or in an error state

Operate the Rimage 2000i

This section includes information about how to power on and off the Rimage 2000i, pause the system, and load discs. It also provides instructions for setting your printing preferences.

Power On the Rimage 2000i

! **Important!** You must power on the Rimage 2000i before you power on the PC. If the PC starts before the Rimage 2000i is powered on, your operating system will not recognize the autoloader and it will not initialize properly.

Press the **power switch** on the back of the Rimage 2000i. The power indicator light illuminates solid green.



Power Off the Rimage 2000i

Press the **power switch** on the back of the Rimage 2000i. The power indicator light dims.

Pause the Rimage 2000i

Before you load or unload discs, you must pause the Rimage 2000i.

1. Press and release the **operator button** to pause the autoloader. [RIMAGE 2000i PAUSED...] displays on the operator panel.
2. Press the **operator button** again to return to normal operation.



Load Discs

The supply bin holds up to 100 discs. Use discs that are coated with an ink-jet printable surface. The media in Rimage Media Kits™ are designed for optimum print performance.

Use the following procedure to load discs into the supply bin.

1. Press and release the **operator button** to pause the Rimage 2000i.
2. Gently move the **disc diverter** to the right.



3. Place the **discs** in the supply bin so the recording side faces down.

⚠ **Important!** Hold the discs by the edge. Fingerprints on the disc surface can affect print quality.

📖 **Tip:** Separate the media to make sure that the discs do not stick together.



4. Move the **disc diverter** to the left.

5. Press and release the **operator button** to return to normal operation.



Set Your Printing Preferences on a Windows-based PC

Printing preferences allow you to set up your Rimage 2000i to produce the best possible label on your discs. Through printing preferences, you can:

- *Set the print quality*
- *Create, edit, or delete a watermark*
- *Adjust the ink volume used*
- *Set color options*
- *Set the printable area*
- *Align the ink cartridges*
- *Center the image on the disc*
- *Check the ink levels*

📖 **Tip:** For additional information about these features, access the online help in the *Disc Color 480i Printing Preferences* window.

Access Printing Preferences

You must access the *Disc Color Printer 480i Printing Preferences* window to set up your printing preferences. Use one of the following procedures to access the *Disc Color Printer 480i Printing Preferences* window through the Windows Start menu or through CD Designer.

Access Printing Preferences through Windows Start Menu

 **Note:** When you use this method, your printing preferences are saved in the printer driver settings.

1. In Windows select: **Start > Printers and Faxes**.
2. Right-click on **Disc Color Printer 480i** and select **Printing Preferences** from the dropdown menu. The *Disc Color Printer 480i Printing Preferences* window opens.

Access Printing Preferences through CD Designer

 **Note:** When you use this method, your printing preferences are saved with the label file and are used instead of the printer driver settings.

1. In CD Designer, open the desired **label file**.
2. From the **File** menu, select **Print**. The *Print* window opens.
3. From the **Printer Name** dropdown list, select **Disc Color 480i**.
4. Select **Document Properties**. The *Disc Color 480i Properties* window opens.

Set the Print Quality

Use this procedure to set the print quality for your discs.

1. [Access Printing Preferences](#). Refer to page 15.
2. Select the **Disc/Quality** tab.
3. In the *Disc Options* section, select the appropriate **Type** from the dropdown list.
4. In the *Print Quality* section, select the desired **print quality**. The following information about the quality displays:
 - Black render dpi
 - Color input dpi
 - Color output
5. When you have made the desired choices, select **Apply**.
6. Select **OK**. The *Preferences* window closes.

Create, Edit, or Delete a Watermark

This functionality allows you to create a watermark to print on your disc. You can also edit an existing watermark or delete an a watermark that you have previously created.

 **Note:** You can only delete watermarks that you or another user has created. You cannot delete any of the default watermarks.

1. [Access Printing Preferences](#). Refer to page 15.
2. Select the **Effects** tab.
3. From the **Watermarks** dropdown list, select a **watermark**.
4. Create, edit or delete a watermark.
 - To create a new watermark or edit an existing watermark:
 - a. Select **Edit**. The *Watermark Details* window opens.
 - b. If you are creating a new watermark, select **New**. “Untitled” displays in the **Current Watermarks** field.
 - c. Enter or change information in one or more of the following fields:
 - **Watermark Message:** Enter the desired message.
 - **Message Angle:** Select the appropriate option button to provide the desired angle. If you select the Angle option button, you can set the angle.
 - **Options:** Select the Justified Across Page option button to center and justify the text.
 - **Font Attributes:** Select the desired font attributes from the dropdown lists.
 - d. If you want the watermark to print only on the first disc, select the **First Page Only** checkbox.
 - e. When you have made the desired additions or changes, select **Apply**.
 - To delete an existing watermark:
 - a. Highlight the desired **watermark** in the *Watermark Details* window.
 - b. Select **Delete**.
5. Select **OK**. The *Watermark Details* window closes.
6. Select **OK**. The *Preferences* window closes.

Adjust the Ink Volume Used

This functionality allows you to adjust the amount of ink that is used during printing.

1. [Access Printing Preferences](#). Refer to page 15.
2. Select the **Basics** tab.
3. Select **Advanced Features**. The *Advanced Features* window opens.
4. Move the **Ink Volume** and **Dry Time** sliders to increase or decrease the ink volume or dry time.
 - ⓘ **Important!** Do not select the **Low Memory** checkbox.
5. Select **OK**. The *Advanced Features* window closes.
6. Select **Apply** to save your changes.
7. Select **OK**. The *Preferences* window closes.

Set Color Options

This functionality allows you to toggle between color and grayscale printing, select the type of color space your labels require, and adjust some color attributes.

1. [Access Printing Preferences](#). Refer to page 15.
2. Select the **Color** tab.
3. Turn *Print in Grayscale* on or off.
 - a. In the *Color Options* box, select or clear the **Print in Grayscale** checkbox.
 - b. If you selected the checkbox, select the appropriate **option button** for your print type.
4. Move the **Saturation**, **Brightness**, and/or **Color Tone** sliders to the desired position to adjust color attributes.
5. If necessary, select the appropriate **Color Space** from the dropdown list.
6. When you have made the desired choices, select **Apply**.
7. Select **OK**. The *Preferences* window closes.

Set the Printable Area

This functionality allows you to adjust the non-printable area, or mask settings, for standard CD/DVD 120 mm media. The mask settings allow you to control the outer and inner diameters so that the printed image does not overlap the disc edges. If you print on areas of the disc where the surface is not suitable for printing, the ink can smear or run.

1. [Access Printing Preferences](#). Refer to page 15.
2. Select the **Mask Settings** tab.
3. Measure the **printable area** and adjust the settings.
 - If you use hub printable discs with a stacking ring:
 - a. In the *Hub Area Settings* box, select the **Printing on Hub** checkbox to print on the disc hub.

 **Tip:** Some older discs have a printable hub and a gap for the stacking ring. If you have media like this, use the following printable areas:

Standard Area

- Outer Diameter 118 mm
- Inner Diameter 38 mm

Hub Area

- Outer Diameter 35 mm
- Inner Diameter 24 mm



Disc with Stacking Ring

- b. Measure the **inner diameter** of the printable surface.
- c. In the **Hub Area Settings** field, enter the inner diameter that you measured in step b.
- d. Measure the **outer diameter** of the printable hub area.
- e. In the **Hub Area Settings** field, enter the outer diameter that you measured in step d.
- f. Measure the **inner diameter** of the standard printable area.
- g. In the **Standard Area Settings** field, enter the diameter that you measured in step f.



- If you use hub-printable discs without a stacking ring:
 - a. Measure the **inner diameter** of the printable surface.
 -  **Tip:** Most discs like the one shown above have the following printable areas:
 - Outer Diameter 118 mm
 - Inner Diameter 24 mm
 - b. In the **Hub Area Settings** field, change the *Outer Diameter* and *Inner Diameter* settings to the value measured in step a before changing any other diameter settings.
 - c. In the **Standard Area Settings** field, change the *Inner Diameter* to the same value used in step b.
- 4. Select **Apply** to use your changes.
- 5. Select **OK**. The *Preferences* window closes.



Disc without Stacking Ring

Align the Ink Cartridges

For optimal print quality and maximum printing speed, use the following procedure to align the ink cartridges.



1. [Access Printing Preferences](#). Refer to page 15.
2. Load a disc (Qty. 1) in the printer.
 - a. Press . The printer tray opens.
 - b. Place a **120 mm white disc** (Qty. 1) on the tray.
3. Check the **ink cartridge alignment**.
 - a. From the *Preferences* window, select the **Service** tab.
 - b. Select **Service ToolBox**. The *Service ToolBox* dialog box opens.
 - c. Select **Align Cartridges**. The *Align Cartridges for Disc Color Printer 480i* dialog box opens.
 - d. Follow the **onscreen prompts** to complete the alignment.
 - e. When the alignment is complete, select **OK**. The *Align Cartridges for Disc Color Printer 480i* dialog box closes.
4. Select **OK**. The *Preferences* window closes.
5. Press . The printer tray closes.

Center the Image on the Disc

The Rimage 2000i provides two ways to center the image on the disc. You can use the *Auto Centering* method or the *Manual Centering* method. The following procedure describes both methods. The Auto Centering method is accurate to within +/- 0.5 mm. You can improve the centering position accuracy with the Manual Centering adjustment to better than +/- 0.2 mm.

 **Tip:** Use the *Center Image* functionality only if the printed image is not centered on the disc. Image centering is set by the manufacturer and usually does not need to be recalibrated in the field.

For optimal print quality, use the following procedure to center the image on the disc.

1. [Access Printing Preferences](#). Refer to page 15.
2. Press . The printer tray opens.
3. Place a **120 mm white disc** (Qty. 1) on the tray.
4. On the **Service** tab, select **Service ToolBox**. The *Service ToolBox* dialog box opens.
5. Select **Center Image**. The *Centering Margins for Disc Color Printer 480i* dialog box opens.
6. Follow the **onscreen instructions** to use either the *Auto Centering* or the *Manual Centering* method.
7. When the image is centered, select **OK**. The *Centering Margins for Disc Color Printer 480i* dialog box closes.
8. Select **OK**. The *Rimage Service ToolBox* dialog box closes.
9. Select **OK**. The *Preferences* window closes.
10. Press . The printer tray closes.

Check the Ink Levels

This functionality allows you to check the current levels of ink in the cartridges.

 **Tip:** If you remove the ink cartridges and reinsert them, the system resets to show that the cartridges are full, regardless of the actual fill status.

1. [Access Printing Preferences](#). Refer to page 15.
2. On the **Service** tab, select **Service ToolBox**. The *Service ToolBox* dialog box opens.
3. Select **Get Ink Level**. Ink level information displays in the **Printer Status** field.
4. Select **OK**. The *Rimage Service ToolBox* dialog box closes.
5. Select **OK**. The *Preferences* window closes.

Maintain the Rimage 2000i

Regular preventative maintenance of your Rimage 2000i can help to ensure error-free recordings and clean printed labels. Maintenance involves cleaning the system, cleaning the ink cartridges, and replacing the fan filter.



Use the information in this section to keep your Rimage 2000i in optimum operating condition.

⚠ Caution: To avoid damaging the Rimage 2000i during maintenance:

- Never use oils, silicone, or other lubricants on any part of your Rimage 2000i.
- Use only non-abrasive cleaners to wipe down the surfaces of your Rimage 2000i.
- Do not pour cleaner directly onto your Rimage 2000i. Instead, apply the cleaner to a lint-free cloth first.
- When you spray compressed air, make sure that no liquid drips into your system.

Preventative Maintenance Schedule

! **Important!** Failure to follow the maintenance schedule outlined below may void your warranty.

Materials	Task	Frequency
Mandatory		
Lint-free cloth Non-abrasive, all-purpose cleaner	<ol style="list-style-type: none"> 1. With the Rimage 2000i powered on, place your hand next to the fan to make sure that the fan is operating.  Tip: If you do not feel air blowing, the fan is not operating and must be replaced. Contact your Rimage reseller. 2. Power off the Rimage 2000i. 3. Disconnect the power cord. 4. Wipe down all exterior surfaces of the autoloader.  Tip: Your system may require more frequent maintenance if it is used in a dusty area, such as a store or warehouse. 	Weekly
Dry, lint-free cloth	Wipe down the glide strips where the lift arm rollers touch the system. 	Weekly

The preventative maintenance schedule is continued on page 22.

Materials	Task	Frequency
Mandatory, continued		
New fan filter	Replace the fan filter . Refer to the Replace the Fan Filter instructions on page 24.	Monthly
Can of compressed air Torx T10 screwdriver	Remove dust from the system. Refer to the Remove Dust from the Rimage 2000i instructions on page 22.	Monthly
New ink cartridges	Replace the ink cartridges. Refer to the Replace the Ink Cartridges instructions on page 25.	As needed
Optional		
None needed	Clean the ink cartridges. Refer to the Clean the Ink Cartridges instructions on page 24.	When print quality problems are noticed
Torx T25 screwdriver 11/32" nut driver 5/32" Allen wrench	Align the printer. Refer to the Align the Printer instructions on page 27.	As needed  Note: The printer is aligned at the factory.

Remove Dust from the Rimage 2000i

Required tools:

- Can of compressed air
- Torx T10 screwdriver

1. Press the **recorder buttons** to open the recorder trays.
2. Power off the **Rimage 2000i**.
3. Disconnect the **cables** from the back of the system.

⚠ Caution: Some cables in this system are latched. Equipment damage may occur if cables are not disconnected appropriately.

- **Power cord**
- **USB cable**

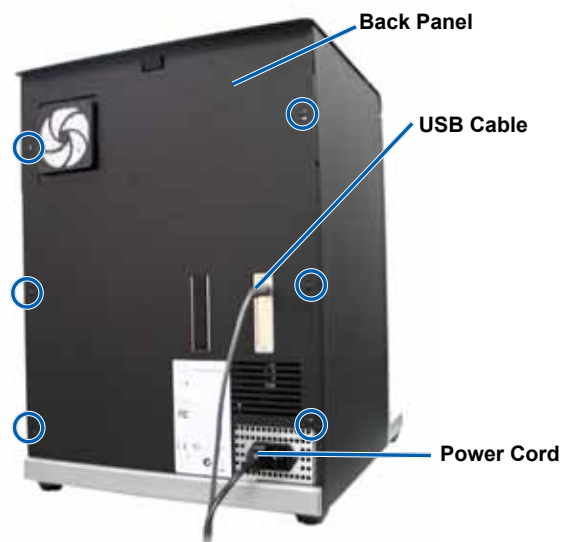

4. Remove the **back panel**.
 - a. Remove the **Torx T10 screws** (Qty. 6) that secure the back panel.
 - b. While firmly grasping the top of the **back panel**, lift and pull back to remove it.
5. Slide the **left side panel** straight back and off of the system.

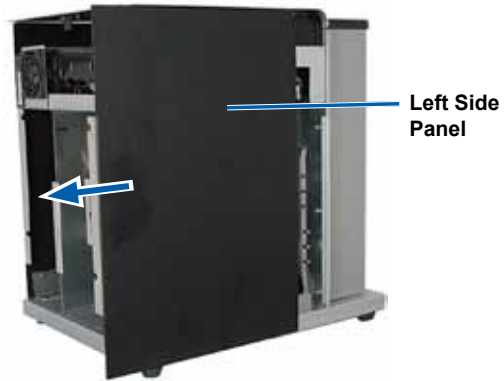

6. Remove the **dust**.
 - a. Spray the **compressed air** through the recorders from front to back.
 - b. Open the **ink cartridge access door**.
 - c. Spray the **compressed air** through the printer from front to back.



- d. Open the **printer access door**.
 - e. Spray the **compressed air** from the hinges of the printer access door to the back of the system.

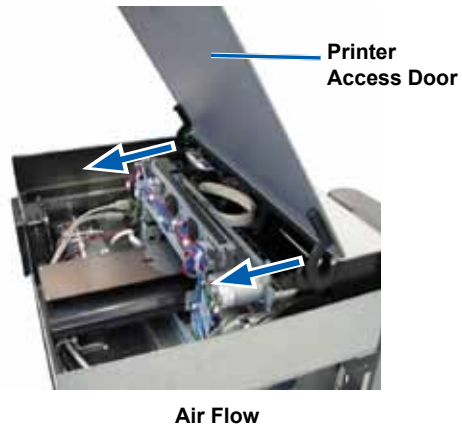

- f. Spray the **compressed air** from the front to the back of the system, across the USB hub and the power supply.



7. Slide the **left side panel** into place.
8. Position the **back panel** on the system.
9. Install and tighten the **Torx T10 screws** (Qty. 6) to secure the back panel.
10. Connect the cables at the back of the system.
 - **Power cord.**
 - **USB cable**
11. Power on the **Rimage 2000i**.
12. Press the **recorder buttons** to close the recorder trays.

Clean the Ink Cartridges

This functionality allows you to clean the ink cartridge nozzles. The nozzles may become clogged from dried ink, causing poor print quality.

1. [Access Printing Preferences](#). Refer to page 15.
2. Select the **Service** tab.
3. On the **Service** tab, select **Service ToolBox**. The *Service ToolBox* dialog box opens.
4. Select **Clean Cartridges**. The *Cleaning Cartridges* window opens.
5. Select **Light** to clean the ink cartridge nozzles with the least amount of ink. When the cleaning is complete, a message displays in the **status** field at the bottom of the *Cleaning Cartridges* window.
 -  **Note:** Print a test disc after you clean the ink cartridge nozzles. If print quality is still poor, repeat **step 1 - step 5**, selecting **Medium** or **Heavy** in step 5.
6. Select **OK**. The *Cleaning Cartridges* window closes.
7. Select **OK**. The *Rimage Service ToolBox* dialog box closes.
8. Select **OK**. The *Preferences* window closes.

Replace Consumables

This section provides information about replacing the fan filter and ink cartridges in the Rimage 2000i.

Replace the Fan Filter

The fan filter is a consumable item. You must change the fan filter every month. Use the following procedure to change the fan filter.

1. On the back of the Rimage 2000i, firmly grasp a corner of the **fan filter retainer**.
2. Gently pull the **fan filter retainer** away from the back of the Rimage 2000i.
3. Remove the **fan filter**.
4. Place the new **fan filter** in the **fan filter retainer**.
5. Firmly press the **fan filter retainer** into the slots on the back of the Rimage 2000i until it snaps into place.



Replace the Ink Cartridges

Use the following procedure to change the ink cartridges in your Rimage 2000i.

⚠ **Important!** You must use the appropriate ink cartridges in one of the configurations listed in the [Ink Requirements](#) section. Refer to page 9.

1. Lift the **ink cartridge access door**. The ink cartridge carriage moves to an accessible position on the carriage guide.
2. When the ink cartridge carriage stops, lift the **ink cartridge latch** to the open position.

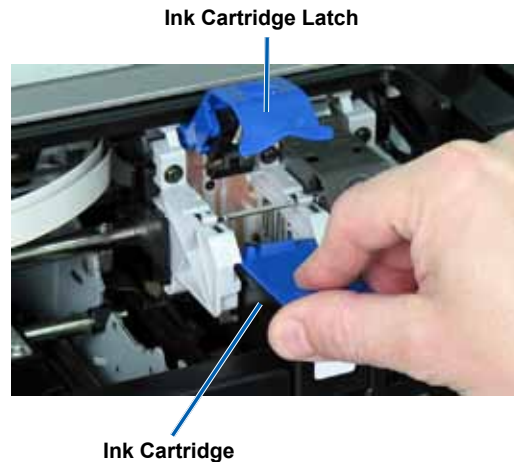

3. If an ink cartridge is already installed, slide the **ink cartridge** out of the ink cartridge cradle.
4. Remove a new **ink cartridge** from the packaging.
5. Carefully remove the **protective tape** that covers the ink nozzles.
- ⚠ **Important!** Do not touch the nozzles or the copper contacts on the ink cartridges. If you touch these parts, clogs, ink failure, and poor electrical connections are likely to occur. Do not remove the copper strips.
6. Hold the **ink cartridge** so that the copper strip is on the bottom, facing toward the printer.
7. Slide the **ink cartridge** into the cradle.
8. Push down on the **ink cartridge latch** until it snaps into place.
9. Close the **ink cartridge access door**. The ink cartridge status light flashes for a few seconds. When the status light stops flashing, the Rimage 2000i is ready to print.

 **Note:** If the ink cartridge is not securely seated in the cradle, the printer will not recognize the ink cartridge. The printer may not reset properly or you may receive an invalid ink cartridge message. If this happens:

- Remove the **ink cartridge** and reinsert it. Be sure to press firmly when you reinsert it.
- Make sure to use the appropriate ink cartridge. Acceptable cartridges are listed in the [Ink Requirements](#) section on page 9.
- If the problem persists, replace the **ink cartridge**.



10. Align the **ink cartridges**. Refer to [Align the Ink Cartridges](#) on page 18.

Diagnostic Tests

This section provides the information needed to access, select, and perform Rimage 2000i diagnostic tests. Before you begin, make sure that the Rimage 2000i is not in an error state.

⚠ **Important!** Perform only the diagnostic tests provided below. Do not attempt to perform other diagnostic tests without the assistance of a Rimage trained technician.

Access Diagnostic Test Mode

1. Power on the **Rimage 2000i**.
2. Allow the system to fully initialize.
 **Note:** It can take up to 5 minutes for the Rimage 2000i to initialize.
3. Press and hold the **operator button** until [BUTTON DIAGNOSTIC] displays on the operator panel.
 **Note:** Other status messages display on the operator panel while you press the operator button. Do not release the button until [BUTTON DIAGNOSTIC] displays on the operator panel.
4. Release the **operator button**. The Rimage 2000i is in diagnostic test mode.

Select a Diagnostic Test

1. Press the **operator button** the same number of times as the test number, holding the button in on the last press to start the selected test.
For example, to start Diagnostic Test 3 (Calibrate Diagnostic), press the **operator button** three times and hold it in on the third press.
 **Tip:** To display each diagnostic test number and name, press the operator button at a rate that is slow enough to read the test on the operator panel. If you hold the button too long, the test begins.
2. Continue with the desired diagnostic test.

Diagnostic Test 3 – Calibrate Diagnostic Test

This test uses one disc to calibrate the distance from the lift arm home position to the supply bin.

1. Access and select **diagnostic test 3**. Refer to [Access Diagnostic Test Mode](#) on page 17.
2. Press the **operator button** three times and hold it in on the last press. [STARTING TEST RELEASE BUTTON] displays on the operator panel.
3. Release the **operator button**. [PLACE ONE DISC INTO SUPPLY BIN PRESS/REL to GO] displays on the operator panel.
4. Place one **disc** into the supply bin.
 **Caution:** Make sure that there is only one disc in the supply bin. If you attempt to perform this test with more than one disc in the system, miscalibration will occur. Miscalibration can cause damage to the lift arm and recorders.
5. Press and release the **operator button**.
 - The lift arm moves to the supply bin and picks up the disc.
 - The lift arm releases the disc into the supply bin.
 - The lift arm moves back to its home position above the printer tray.
 - The Rimage 2000i exits diagnostic test mode and the system restarts.

Align the Printer on the Rimage 2000i

The printer is aligned at the factory. However, the printer can come out of alignment during shipping. If the lift arm is not picking or placing discs on the printer tray properly, or if you receive clamping errors, you need to align the printer. Use the following procedure to align the printer.

Required tools:

- Torx T25 screwdriver
- 11/32" nut driver
- 5/32" Allen wrench

1. Stop or pause all **jobs**.
2. Make sure that the **printer cables** are connected.
3. Test the **printer alignment**.
 - a. Make sure the **printer tray** is closed.
 - b. Access **diagnostic test mode**. Refer to the [Access Diagnostic Test Mode](#) section on page 17
 - c. Press the **operator button** four times and hold it in on the fourth press. [JOG LIFT DIAGNOSTIC] displays on the operator panel. This lift arm moves to the top of the lift column.
 - d. When [STARTING TEST RELEASE BUTTON] displays on the operator panel, release the **operator button**.
 - e. Press . The printer tray opens.
 - f. Place a **disc** (Qty. 1) on the printer tray so that the two small pins are aligned at the front of the hole in the disc, and the disc lays flat on the printer tray. Refer to the images below.

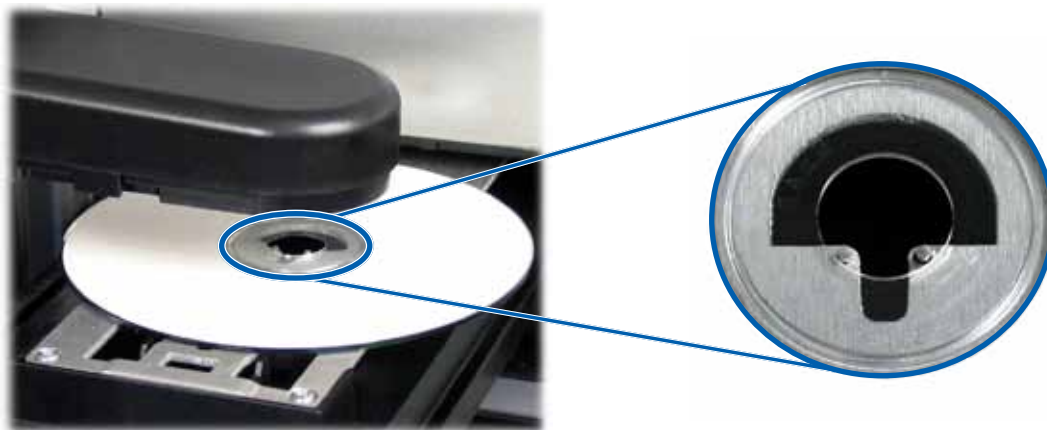

- g. Press the **operator button**. The lift arm picks up the disc.
- h. Press the **operator button** again. The lift arm releases the disc onto the printer tray.
 - If the printer is properly aligned, the lift arm smoothly sets the disc onto the printer tray, and the disc sits on the printer tray as shown in the photos above
 - The two small pins are aligned at the front of the hole in the disc.
 - The disc lays flat on the printer tray.
 - If the disc is seated on the printer tray as shown above, the printer is aligned. Remove the disc from the printer tray and continue to **step 9**.
 - If the disc is not seated on the printer tray as shown above, you must align the printer. Continue to **step 4**.

4. Access the **printer**.

- a. Open the **printer service door** to access the hex nuts at the rear of the printer.

 **Note:** You may need to prop this door open or have someone hold the door for you.

- b. With the 11/32" nut driver, loosen the **hex nuts** (Qty. 2) at the rear of the printer. The printer frame loosens, allowing you to use the alignment screws (Qty. 3) to align the printer in step 6.

 **Note:** The purpose of the hex nuts is to hold the printer securely during shipment. Tightening these nuts after alignment is optional.

- c. Close the **printer service door**.

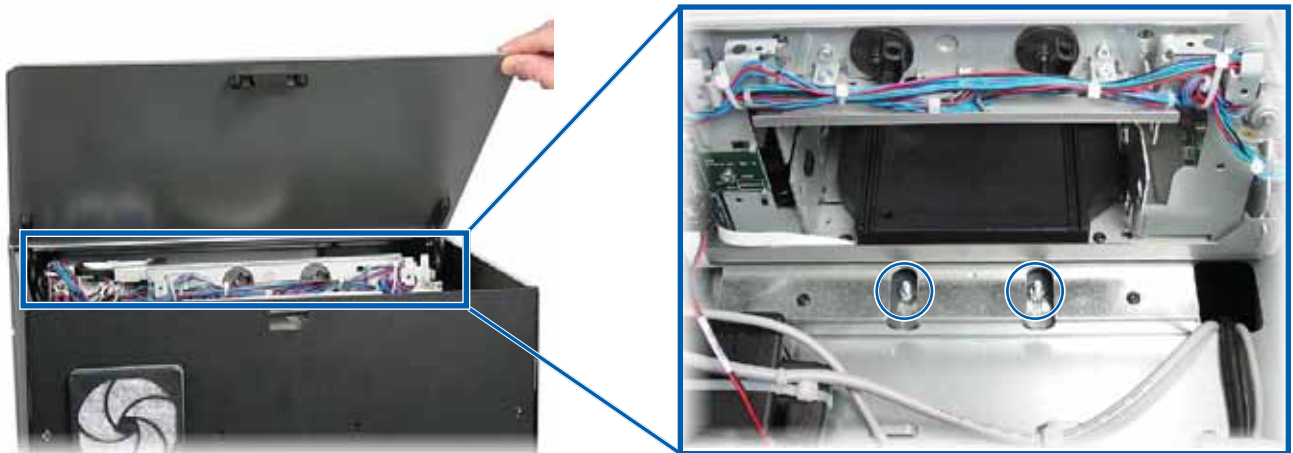

Hex Nuts

5. Open the **ink cartridge access door**.

6. Align the **printer** from side to side.

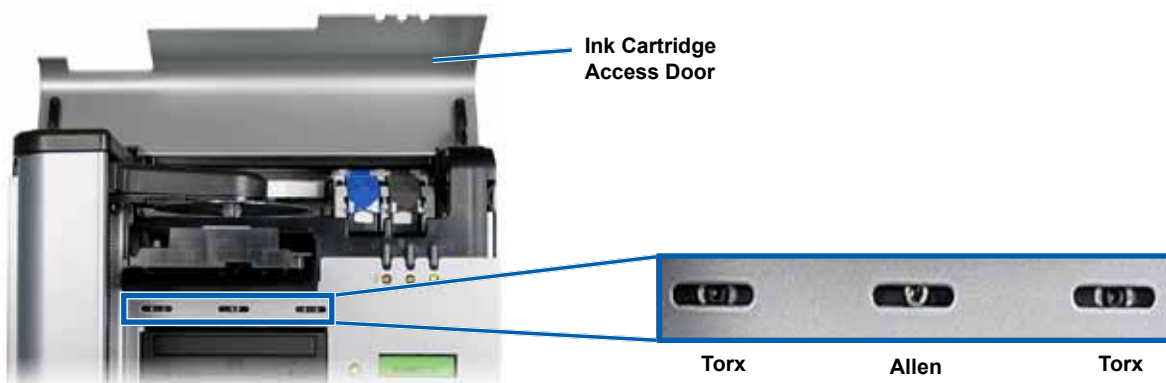

 **Note:** If the printer must be aligned front to back, continue to **step 7**.

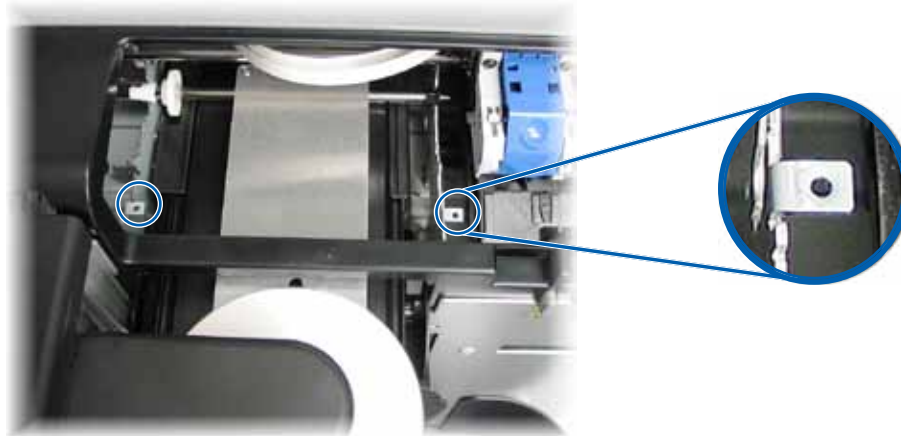

- a. Loosen the **Torx T25 screws** (Qty. 2) at the front of the printer until you can move the printer from side to side.
- b. Gently grasp the small **metal tabs** (Qty. 2) on the printer.



Metal Tabs

- c. Move the **printer** to the left or right as needed.
 - d. Repeat **step 3** to check the printer alignment.
 - e. If necessary, repeat **step b - step d** until the printer is properly aligned from side to side.
 - f. When the printer is properly aligned, tighten the **Torx T25 screws** (Qty. 2) to ensure continued alignment.
7. Align the **printer** from front to back.
 - a. Using a 5/32" Allen wrench, turn the **center front 5/32" Allen screw** (Qty. 1).
 - Turn the **Allen screw** clockwise to move the printer toward the front of the Rimage 2000i.
 - Turn the **Allen screw** counterclockwise to move the printer toward the back of the Rimage 2000i.
 - b. Repeat **step 3** to check the printer alignment.
 - c. If necessary, repeat **step 7** until the printer is properly aligned from front to back.
 8. Remove the **disc** from the printer tray.
 9. Press . The printer tray closes.
 10. Close the **ink cartridge access door**.
 11. Press and hold the **operator button** until [EXIT TEST MODE DIAGNOSTIC] displays on the operator panel.
 12. When [EXIT TEST MODE DIAGNOSTIC] displays on the operator panel, release the **operator button**.
-  **Note:** If [PAUSE...] displays on the operator panel, press and release the operator button. [RIMAGE 2000i READY] displays on the operator panel.

The Rimage 2000i is ready for use.